

## 1. Introduction

Many industrial processes need pure water, free from particles and other impurities. Modern water supplies are often severely polluted; this puts heavy demands on purification and filtration equipment. A good system must be simple, efficient and reliable.

In 1990 Mr. Ulf Steiner and his R&D team developed a filter for protection of plate heat exchangers in seawater cooling systems. The filter was designed to ensure high operational reliability and very simple maintenance. It was also designed to be corrosion-free in seawater, with few moving parts and with a good choice of materials.

The **Bernoulli Filter** had been invented.

The Bernoulli Filter is an ingenious design for water filtration. The cleaning of the filter works on Bernoulli's principle, a discovery more than 250 years old, which states that an increase in a fluid's flow velocity gives rise to a drop in static pressure. In the Bernoulli Filter, a specially designed disc is introduced into the filter basket, creating an increase of the flow velocity between the disc and the wall of the basket. The resulting drop in static pressure "vacuums" away the particles which are stuck to the inside of the basket. The impurities are then flushed out through a flushing valve. Problems due to clogging of the basket are thereby avoided. All of this is done without interrupting the normal filtration process.

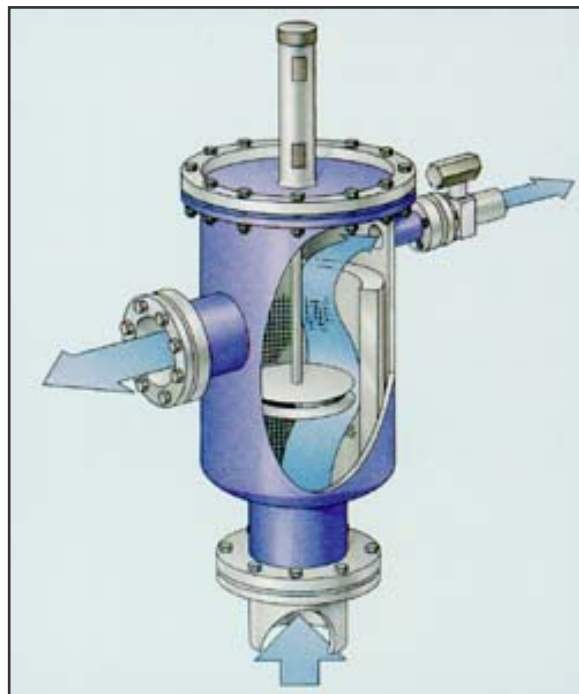

Figure 1.1. The Bernoulli Filter

## 2. The Bernoulli principle

### 2.1 General knowledge

Bernoulli's principle is a relationship between the elevation, pressure and speed of a fluid (a fluid is either a liquid or a gas). The relationship comes from the conservation of energy (no energy can be destroyed or created). If there are no elevation changes, then the Bernoulli equation states that an increase in a fluid's velocity gives rise to a decrease in its static pressure. "Static pressure" is the correct term but a more common term is simply "pressure."

This is the written form of the equation stating the Bernoulli principle:

$$p_1 + \frac{v_1^2}{2} \cdot \rho + \rho \cdot g \cdot h_1 = p_2 + \frac{v_2^2}{2} \cdot \rho + \rho \cdot g \cdot h_2$$

where

- $p$  = static pressure (or just "pressure")
- $v$  = velocity of the fluid
- $\rho$  = density of the fluid
- $g$  = gravitational constant
- $h$  = elevation from a chosen ground level

The indices "1" and "2" stand for two different sections along a streamline in the fluid.

In figure 2.1 a pipe with a decreasing cross section area,  $A$ , is shown. According to the continuity equation the volume flow through the pipe,  $V$ , is constant if the flow is steady state (no variations with time). The volume flow is given by:

$$V = v \cdot A \quad [m^3/s]$$

As a result, if the cross section area is decreased, the velocity will be increased

In the figure there are no elevation changes between the two sections. That simplifies the equation.

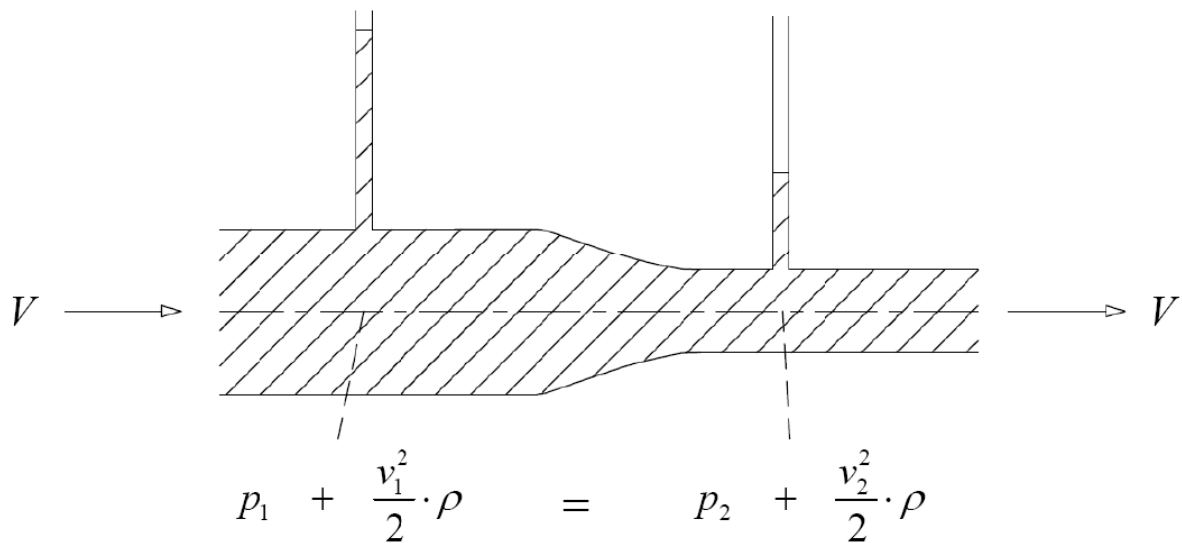

Figure 2.1. A tube with a decreasing cross section area

Since the density ( $\rho$ ) doesn't change in most cases, the Bernoulli equation states that an increase in velocity is accompanied with a decrease in static pressure. In figure 2.1 the difference in pressure can be seen by comparing the heights of the two water columns from the centerline in the pipe.

## 2.2 Bernoulli's principle in the world around us

Bernoulli's discovery can be seen in many aspects of daily life. It is even used in technology (apart from the Bernoulli Filter). Here are a few examples.

A Venturi tube is a tube with a narrow throat, as shown in figure 2.2. The throat speeds up the incoming fluid and thereby decreases its pressure.

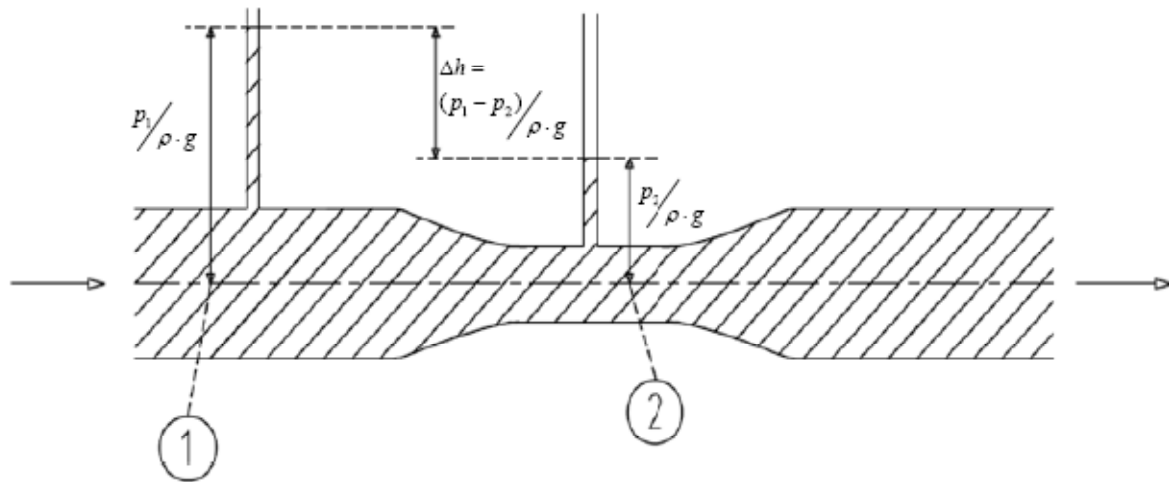

Figure 2.2 Volume flow measurement in a Venturi tube

Methods that use the Venturi/Bernoulli effect are often used to measure flow in piping systems. Volume flow can be calculated by using the continuity equation and the Bernoulli equation:

$$\left. \begin{aligned} v_1 \cdot A_1 &= v_2 \cdot A_2 \\ p_1 + \frac{v_1^2}{2} \cdot \rho &= p_2 + \frac{v_2^2}{2} \cdot \rho \end{aligned} \right\} \Rightarrow v_1 = \sqrt{\frac{2 \cdot (p_1 - p_2)}{\rho \cdot \left( \left( \frac{A_1}{A_2} \right)^2 - 1 \right)}}$$

The volume flow equals the velocity multiplied by the cross section area. Furthermore, the pressure difference  $p_1 - p_2 = \Delta h \cdot \rho \cdot g$ . This gives:

$$V_1 = V_2 = V = A_1 \cdot \sqrt{\frac{2 \cdot g \cdot \Delta h}{\left( \frac{A_1}{A_2} \right)^2 - 1}}$$

Venturis can be used for purposes other than measuring fluid flows. The low pressure created by the narrow throat can be utilized to make it easier to mix two fluids. A carburetor in a reciprocating engine for example, contains a Venturi to create a region of low pressure, drawing fuel into the carburetor and mixing it thoroughly with incoming air. The Bunsen burner, a common piece of laboratory equipment, uses the Venturi/Bernoulli effect to draw air into the gas stream.

Bernoulli's principle is sometimes used to explain why airplanes can fly. This explanation is referred to as "the longer path explanation." Figure 2.3 shows a wing. The top side of

the wing is more curved than the bottom side. The theory uses two nearby air particles at the leading edge of the wing to explain the phenomenon. One of the particles travels over the wing and one travels under the wing. At the trailing edge they reunite. Since the particle travelling over the top goes a longer distance in the same amount of time, it must be travelling faster than the particle travelling on the bottom side. The difference in speed results in different pressures between the top and the bottom side. This is what makes the plane fly.

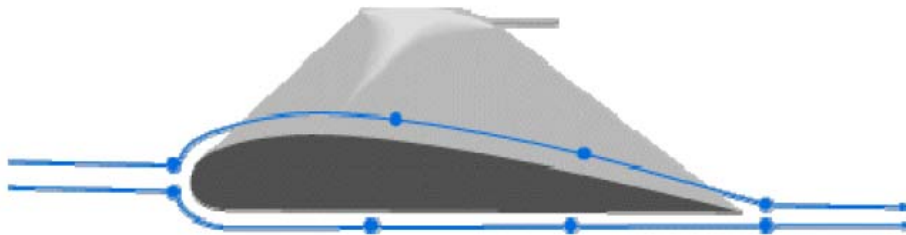

Figure 2.3. The longer path explanation

This theory is not entirely correct, but not entirely wrong either. The assumption that the two air particles reunite at the trailing edge is wrong. They don't know each other's presence and there is no logical reason why these particles should end up at the rear of the wing at the same time. Although many air plane wings have the profile shown in Figure 2.3, some of them are actually symmetrical (shaped identically on the top and bottom surfaces). This explanation also predicts that planes should not be able to fly upside down, which they obviously can.

But the theory is right in that the air on the top surface of the wing is travelling faster than the air on the bottom surface. In fact, it moves faster than the speed required for the air particles to reunite. The static pressure is also higher on the bottom side than on the top side (not surprisingly).

The Bernoulli effect *is* present when lift is created. Some wings are symmetrical because they have a different angle of attack than wings shaped like the one in figure 2.3. The different angle of attack makes the wing “behave” like the wing profile in the figure.

The Bernoulli effect is also present at the sails in a sail boat, at turbine blades and at curved free kicks in soccer.

### **3. Operation of the filter**

#### **3.1 Normal operation**

Dirty water enters the filter's inlet (N1). The water flow turns 90° and passes through the filter basket, where particles larger than the filtration degree are obstructed from passing through. As a result, clean water flows out through the outlet (N2) of the filter. At this time, the flushing outlet (N3) is closed and the piston mounted in the end cover remains outside the filter basket (see Figure 3.1).

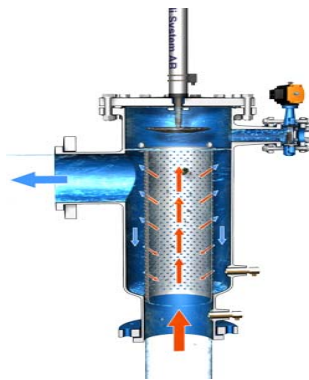

Figure 3.1. Normal operation

#### **3.2 Flushing**

The flushing operation cleans the filter basket.. It can be initiated in any of three ways:

- Manually, by switching the main switch on the control panel off/on. The flushing operation whenever the switch is turned on (note the delay if  $T3 \neq 0$ ).
- When the time T1 has been reached. T1 is set on the control panel.
- The differential pressure switch signals to the control panel to start a flushing sequence. This is done when the filter basket is clogged to approximately 2/3 of its length.

##### **3.2.1 Timed flushing**

When the time T1 has been reached, the flushing valve opens and large particles are flushed out (see Figure 3.2). This avoids large particles later getting stuck between the disc and the basket wall.



Figure 3.2. Pre-flushing

The large particles are flushed out during the so called pre-flushing time  $T_2$ . After that the piston starts to move into the filter basket (see Figure 3.3). The piston makes two full strokes (the length of the stroke is approximately  $2/3$  of the basket's length) before returning to its normal position outside the basket. Remaining dirt particles have now been flushed out. The flushing valve then closes.

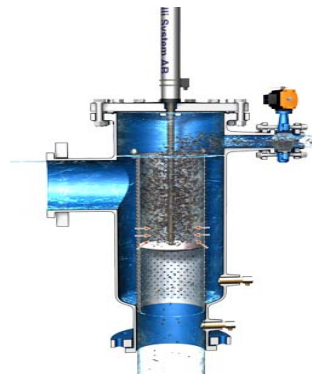

Figure 3.3. Flushing with piston strokes

### 3.2.2 Flushing initiated by the differential pressure switch

If the basket gets clogged to approximately  $2/3$  of its length before the time  $T_1$  is reached, the differential pressure switch signals the control card to start a flushing sequence. The flushing starts and operates in the same way as described in 3.2.1, except that if the basket is not clean after two strokes, the filter does two more.

## **4. How the Bernoulli Filter works – pressure relationships**

### **4.1 Clean filter**

The pressure relations in a clean filter are shown in figure 4.1. At the outlet end, the static pressure inside the basket is higher than the static pressure outside the basket. At the inlet end, the relationship is the opposite. Consequently, particles in the water start to collect at the outlet end of the basket. Due to the pressure relationship at the inlet end, there will be a reversed flow, i.e. a small flow from the outside to the inside of the basket.

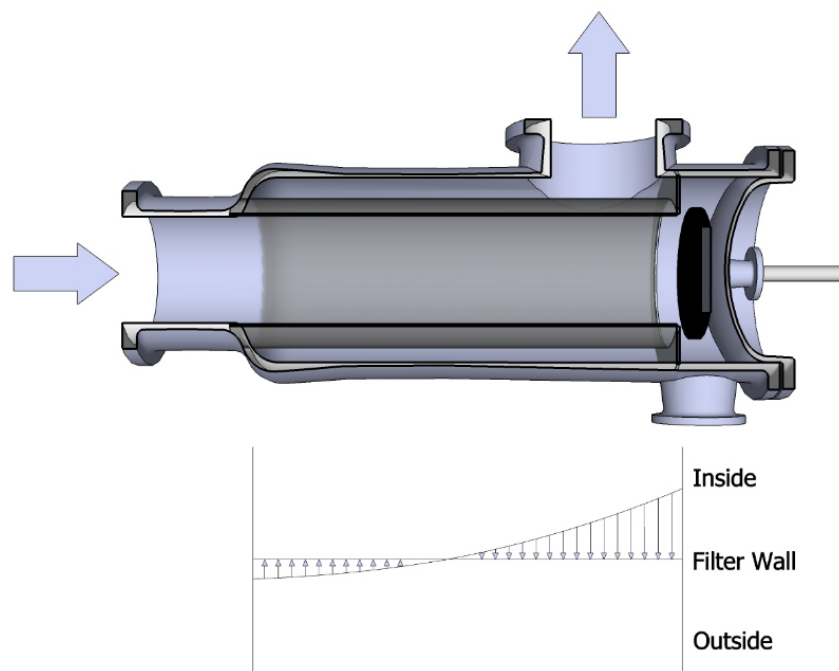

Figure 4.1. Pressure gradients when the basket is clean. Note: In Figures 4.1, 4.3 and 4.4 the “Filter wall” is the wall of the basket, not the wall of the filter body.

Why the pressure situation looks this way can also be explained with the Bernoulli equation. To explain this we use Figure 4.2. The pressure situation in our filters can be shown with the configuration in the figure. Two larger pipes are shown here. Each pipe has one open end (the inlet and the outlet of the filter). The lower pipe represents the inside of the basket; the upper pipe represents the outside of the basket.

Connecting pipes join these two, symbolizing the openings in the filter basket.

In the lower pipe (the inside of the basket) the incoming water at 1a has high velocity. Thus its static pressure is low. The velocity is decreased at the right end of the pipe (1b).



In the filter this happens because the water is close to a physical restraint, the end cover of the filter. Since the velocity is low, the static pressure is high here.

In the upper pipe (the outside of the basket) the pressure situation is the opposite of the situation in the lower pipe. At 2a (the filter outlet) the velocity is high, generating a low static pressure. At 2b the water faces another physical restraint, the filter body wall. The low velocity here leads to a high static pressure.

The flow conditions in the lower and the upper pipe result in the pressure gradients shown in Figure 4.2. The resemblance with the diagram in Figure 4.1 is obvious.

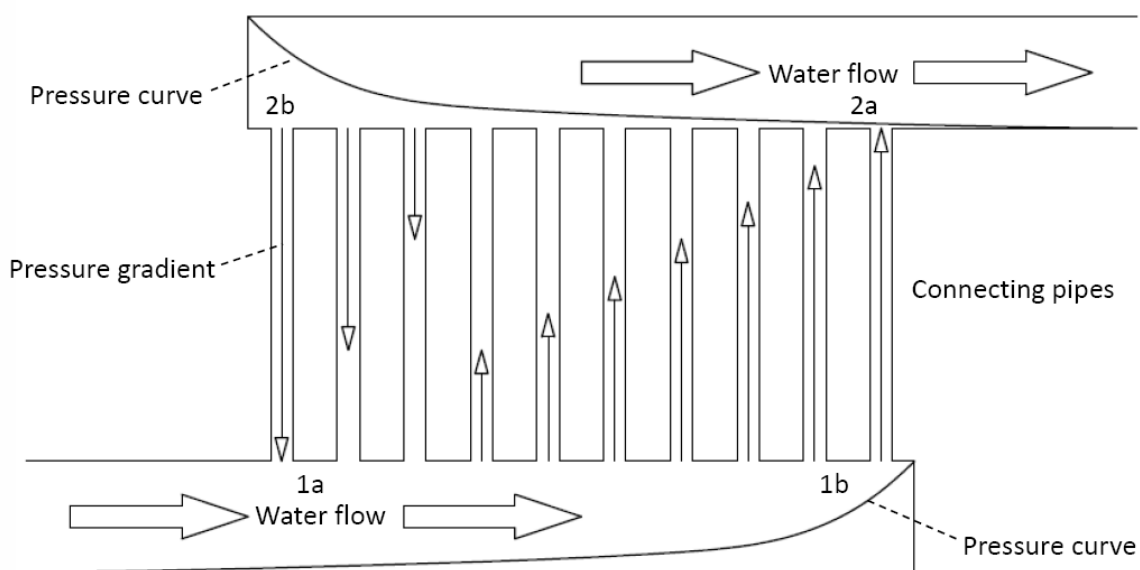

Figure 4.2. A representation of the pressure situation in our filters

The pressure situation in figure 4.2 is the same as in plate heat exchangers with Z-configuration.

## 4.2. Clogged filter

The buildup of particles in the basket starts at the outlet end and continues towards the inlet end. The pressure relationship between the inside and the outside of the basket along the basket's length changes as this build up of particles goes on. Eventually the relationship is as shown in Figure 4.3. At the inlet end, where the connections to the differential pressure switch are located, the outside static pressure is no longer greater than the inside static pressure. The reversed flow has thereby stopped. When the difference between them has reached 1.6psig, the differential pressure switch is triggered. This means that an electrical circuit leading to the control unit is closed. The control unit then starts a flushing sequence. This occurs when the basket has been clogged to approximately 2/3 of its length.

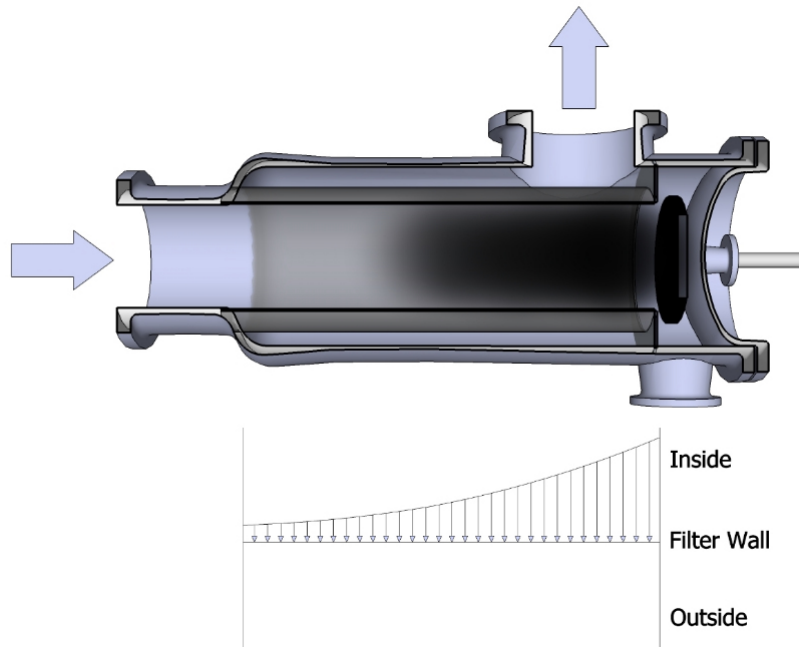

Figure 4.3. Pressure gradients when the basket is clogged

### 4.3. Flushing

The pressure during flushing will vary depending on the position of the disc (see Figure 4.4). Note that the static pressure inside the basket is lower than the static pressure outside the basket around the disc. This is because the water velocity inside the basket is increased as it passes through the gap between the disc and the basket. The increase in velocity leads to a decrease in static pressure. The disc has created a Bernoulli effect! As the static pressure is greater outside the basket than inside it, the particles which are stuck to the basket wall are swept away and flows out through the flushing valve. Note that the Bernoulli effect takes place even when the disc is on its way back (to the right in Figure 4.4).

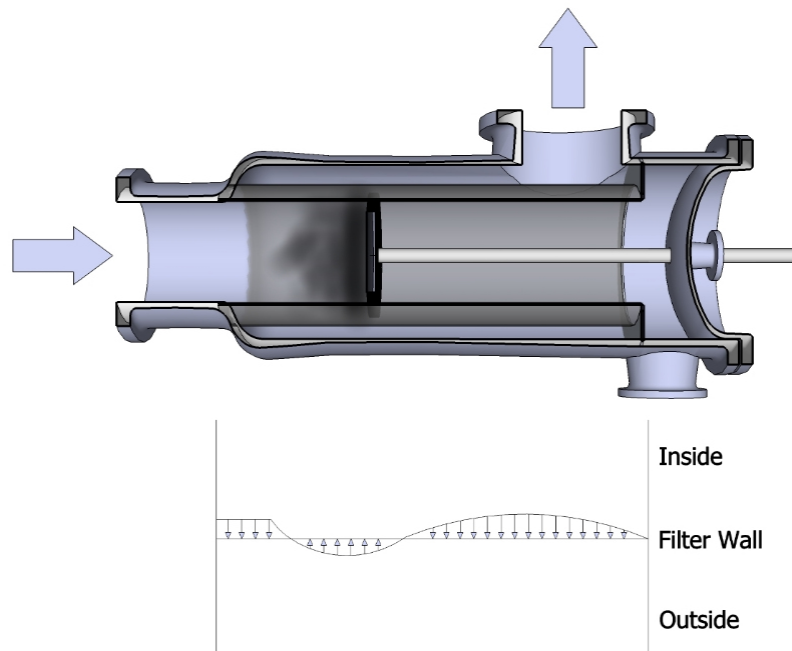

Figure 4.4. Pressure gradients during flushing

#### 4.4. The Bernoulli Filter is a “non-interruption” filter

A big advantage of the Bernoulli Filter is that the normal filtration process continues when the filter is being flushed. It is in fact the main flow in the filter that flushes out the dirt build-up, with the aid of the disc. Since the piston only travels about 2/3 of the basket’s length, the normal filtration process can continue during flushing. The low pressure drop over the filter does not change either. It is the same no matter if the basket is clean, if there is a lot of dirt build-up, or if the filter is being flushed. This relates to the effective open area of the filter.

The effective open area is the area in the filter basket's wall which the water can flow through, divided with the total basket wall area. When the basket is clean, the open area in our baskets is between 20 and 50 percent, depending on the basket type. As more and more dirt collects in the basket, the open area decreases. If the open area sinks below the cross section area of the filter's outlet, N2, the pressure drop over the filter will start to increase. But that never happens in the Bernoulli Filter. The reason is that the differential pressure switch is preset to 1.6 psig. This is the value that occurs when the basket has been clogged to approximately 2/3 of its length.

